

DISPOSABLE PRESSURE SENSITIVE ADHESIVE FIXTURE HOLDS STANDOFF WHILE ADHESIVE CURES.

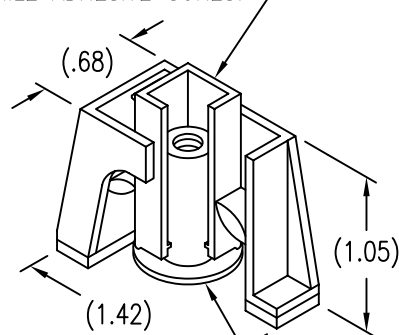

STANDOFF ATTACHED BY ADHESIVE APPLIED TO THIS SURFACE.

LENGTH L DATA (LENGTH L IN SIXTEENTHS OF AN INCH)

CODE	5	6	7	8	9	10	11	12	13	14	15	16	17
L	.312	.375	.437	.500	.562	.625	.687	.750	.812	.875	.937	1.000	1.062
D MIN	.156	.187	.250				.375						

BASEPLATE MATERIAL AND FINISH

CODE	BASEPLATE MATERIAL	FINISH
AX	ALUMINUM	NONE
AA	ALUMINUM	ANODIZED
CR	300 SERIES CRES	PASSIVATE
CRM	316 CRES	PASSIVATE

THREAD AND DIMENSION DATA

CODE	THREAD T	A MAX
440	.112-40 UNC-2B	.217
632	.138-32 UNC-2B	.285
832	.164-32 UNC-2B	
1032	.190-32 UNF-2B	

STANDOFF MATERIAL AND FINISH

CODE	STANDOFF MATERIAL	FINISH
AX	ALUMINUM	NONE
CR	300 SERIES CRES	PASSIVATE

OPTIONAL PRIMER

CODE	BASEPLATE PRIMER
P	EPOXY PRIMER

EXAMPLE PART NUMBER

CN62-1032-10 CR P

OPTIONAL PRIMER COATING ON BASEPLATE  
 STANDOFF MATERIAL (IF DIFFERENT)  
 BASEPLATE MATERIAL - 300 SERIES CRES  
 STANDOFF LENGTH L - .625  
 THREAD SIZE T - .190-32 UNF-2B  
 BASIC PART NUMBER

UNLESS OTHERWISE SPECIFIED, ALL DIMENSIONS ARE IN INCHES AND TOLERANCES ARE AS SHOWN BELOW. DIMENSIONAL TOLERANCES AND SYMBOLS PER ANSI Y14.5M-1982.

PROPRIETARY PARTS SHOWN IN THIS DRAWING ARE THE SUBJECT OF ISSUED UNITED STATES AND FOREIGN PATENTS AND PATENTS PENDING. UNAUTHORIZED REPRODUCTION AND/OR DISTRIBUTION OF THIS DRAWING IS SPECIFICALLY PROHIBITED.

**GLICK BOND**

CARSON CITY  
NEVADA 89706

CAD CN62-1

APPROVALS

DATE

TITLE

STANDOFF, SMALL BASE, ADHESIVE BONDED

ANGLES ±1°

DRAWN DAC 17NOV00

SIZE

CAGE CODE

DWG. NO.

REV.

.XX ±.03

CHECKED DAC 17NOV00

A

66530

CN62

9

.XXX ±.010

RELEASED CGH 17NOV00

SCALE 1/1

17NOV00

SHEET 1 OF 2

.XXXX ±.001

REVISED DAC 17NOV00

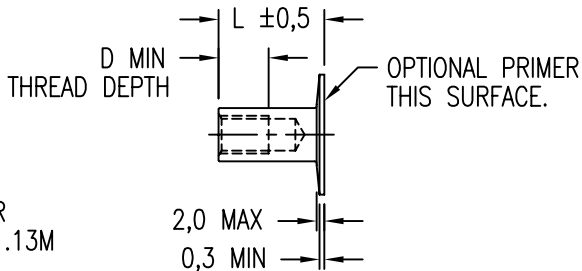
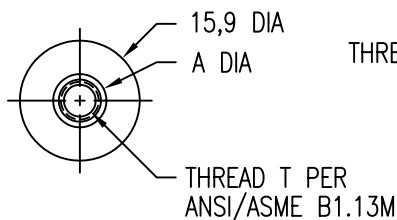

DISPOSABLE PRESSURE SENSITIVE ADHESIVE FIXTURE HOLDS STANDOFF WHILE ADHESIVE CURES.

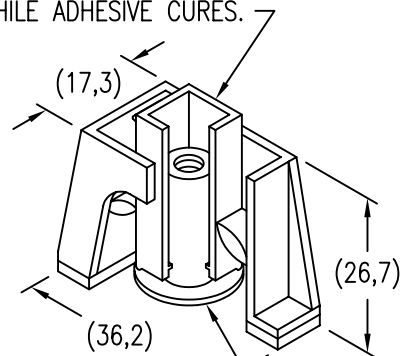

STANDOFF ATTACHED BY ADHESIVE APPLIED TO THIS SURFACE.

LENGTH L DATA (LENGTH L IN MILLIMETERS)

CODE	8M	10M	12M	14M	16M	18M	20M	22M	25M
L	8	10	12	14	16	18	20	22	25
D MIN	4,0	5,0	6,5	9,5					

BASEPLATE MATERIAL AND FINISH

CODE	BASEPLATE MATERIAL	FINISH
AX	ALUMINUM	NONE
AA	ALUMINUM	ANODIZED
CR	300 SERIES CRES	PASSIVATE
CRM	316 CRES	PASSIVATE

THREAD AND DIMENSION DATA

CODE	THREAD T	A MAX
3M	M3 X 0,5 6H	4,35
4M	M4 X 0,7 6H	7,25
5M	M5 X 0,8 6H	

STANDOFF MATERIAL AND FINISH

CODE	STANDOFF MATERIAL	FINISH
AX	ALUMINUM	NONE
CR	300 SERIES CRES	PASSIVATE

OPTIONAL PRIMER

CODE	BASEPLATE PRIMER
P	EPOXY PRIMER

EXAMPLE PART NUMBER

CN62-5M 14M CR P

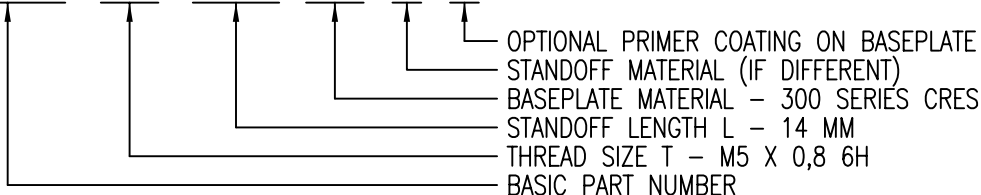

UNLESS OTHERWISE SPECIFIED, ALL DIMENSIONS ARE IN MILLIMETERS AND TOLERANCES ARE AS SHOWN BELOW. DIMENSIONAL TOLERANCES AND SYMBOLS PER ANSI Y14.5M-1982.

PROPRIETARY PARTS SHOWN IN THIS DRAWING ARE THE SUBJECT OF ISSUED UNITED STATES AND FOREIGN PATENTS AND PATENTS PENDING. UNAUTHORIZED REPRODUCTION AND/OR DISTRIBUTION OF THIS DRAWING IS SPECIFICALLY PROHIBITED.

**GLICK BOND**

CARSON CITY  
NEVADA 89706

CAD CN62-2 METRIC DIMENSIONS	
ANGLES	±1°
.X	±0,8
.XX	±0,25

APPROVALS		DATE
DRAWN	DAC	17NOV00
CHECKED	DAC	17NOV00
RELEASED	CGH	17NOV00
REVISED	DAC	17NOV00

TITLE STANDOFF, SMALL BASE, ADHESIVE BONDED			
SIZE	CAGE CODE	DWG. NO.	REV.
A	66530	CN62 (METRIC)	9
SCALE	1/1 17NOV00		SHEET 2 OF 2